

Phase sequence indicator - test plug



Product description	
BALS-Prd.-Nr	2219
EAN	4024941022194
Product category	Phase sequence indicator
Current	32A
Number of poles	5p
Arrangement of phases	3p+N+PE
Position of earth contact	9 h
Voltage	120/208 - 144/250V~
Frequency	50/60Hz

Product description	
Protection degree	IP44
Indication three phases	yes
Motor rotation direction tester	no
Contact less detection of the sense of rotation	yes
Height	143mm
Width	73mm
Depth	73mm

Logistics data	
Weight/pcs	0.255 kg / Piece
Packaging	Bag
Content amount	1 ST
EAN	4024941022194
Length	73 mm
Width	73 mm
Height	143 mm
Weight	0.256 kg
Volume	762.047 ccm

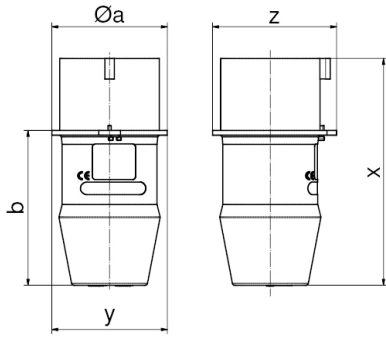

Ampere Polzahl	16 4	16 5	32 4	32 5
$\varnothing a$	58,0	64,0	66,0	73,0
b	76,0	80,0	95,0	98,0
x	112,0	116,0	141,0	144,0
y	58,0	64,0	66,0	73,0
z	63,0	68,0	78,0	79,0